

B&C
EAGLE
QUALITY TOOLS & FASTENERS
WWW.BANDCEAGLE.COM



SN2890
28° CLIP HEAD FRAMING NAILER
OPERATION and MAINTENANCE MANUAL

⚠WARNING:

BEFORE OPERATING THIS TOOL, ALL OPERATORS SHOULD STUDY THIS MANUAL TO UNDERSTAND AND FOLLOW THE SAFETY WARNINGS AND INSTRUCTIONS. KEEP THESE INSTRUCTIONS WITH THE TOOL FOR FUTURE REFERENCE. IF YOU HAVE ANY QUESTIONS, CONTACT YOUR REPRESENTATIVE OR DISTRIBUTOR.

INDEX

Safety Instructions	3, 4
Air Supply: Fittings, Hoses, Filters, Air Consumption, Regulators, Operation Pressure, Setting Correct Pressure	5
Production Specifications	6
Depth Adjustment	7
Loading the Tool	8
Tool Operation	9, 10
Maintaining the Pneumatic Tool	11
Troubleshooting	12

WARRANTY

B&C Eagle brand tools carry a 3 YEAR limited warranty to the original purchaser. If the tool fails within 3 years from the date of purchase, simply return the tool to your nearest B&C Eagle dealer with your receipt. We will repair or replace the tool at NO CHARGE. This limited warranty does not cover any damage that has resulted from abuse or misuse of the tool, and does not cover normal wear parts such as O-Rings, Springs, Bumpers, Driver Units and other consumable items. Be careful, tools are dangerous if improperly used or maintained. Seller's employees are not qualified to advise you on the use of these tools. Oral representation will not be binding on the Seller. The rights under this limited warranty are to the original purchaser and may not be transferred to the subsequent owner. This limited warranty is in lieu of all warranties, expressed or implied including warranties of merchantability and fitness for a particular purpose. Seller shall not be liable for any special, incidental or consequential damages. The sole exclusive remedy against the seller will be for the replacement of any defects as provided herein, as long as the seller is willing or able to repair or replace the tool as provided above. This exclusive remedy shall not be deemed to have failed of its essential purpose.

CUSTOMER SERVICE INFORMATION

Now that you have purchased your tool, should a need ever exist for repair parts or service, simply contact your nearest B&C Eagle dealer or call American Fastening Systems: 1-877-842-1234. Be sure to provide the pertinent facts when you call or visit.

SAFETY INSTRUCTIONS

▲WARNING: **EYE PROTECTION** which conforms to ANSI specifications and provides protection against flying particles both from the **FRONT** and **SIDE** should **ALWAYS** be worn by the operator and others in the work area when connecting to air supply, loading, operating or servicing this tool. Eye protection is required to guard against flying fasteners and debris, which could cause severe eye injury.



The employer and/or user must ensure that proper eye protection is worn. Eye protection equipment must conform to the requirements of the American National Standards Institute, ANSI Z87.1 and provide both frontal and side protection.

NOTE: Non-side shielded spectacles and face shields alone do not provide adequate protection.



CAUTION: Additional Safety Protection will be required in some environments. For example, the working area may include exposure to noise level which can lead to hearing damage. The employer and user must ensure that any necessary hearing protection is provided and used by the operator and others in the work area. Some environments will require the use of head protection equipment. When required, the employer and user must ensure that head protection conforming to ANSI Z89.1 is used.

▲WARNING: Stay alert, watch what you are doing and use common sense when operating a power tool. Do not use tool while tired or under the influence of drugs, alcohol, or medication.

▲WARNING: Dress properly. Do not wear loose clothing or jewelry. Contain long hair. Keep your hair, clothing, and gloves away from moving parts.

▲WARNING: Keep fingers away from trigger when not driving fasteners to avoid accidental firing.

▲WARNING: Do not overreach. Keep proper footing and balance at all times. Proper footing and balance enables better control of the tool in unexpected situations.

▲WARNING: Do not use on a ladder or unstable support. Stable footing on a solid surface enables better control of the tool in unexpected situations.

SERVICE

▲WARNING: Tool service must be performed only by qualified repair personnel. Service or maintenance performed by unqualified personnel may result in a risk of injury.

▲WARNING: When servicing a tool, use only identical replacement parts. Use of unauthorized parts may create a risk of injury.

▲WARNING: Know your pneumatic tool. Read operator's manual carefully. Learn its applications and limitations, as well as the specific potential hazards related to this tool. Following this rule will reduce the risk of electric shock, fire, or serious injury.

▲WARNING: Always wear safety glasses with side shields. Everyday glasses have only impact resistant lenses. They are **NOT** safety glasses. Following this rule will reduce the risk of eye injury.

▲WARNING: Protect your lungs. Wear a face or dust mask if the operation is dusty. Following this rule will reduce the risk of serious personal injury.

▲WARNING: Protect your hearing. Wear hearing protection during extended periods of operation. Following this rule will reduce the risk of serious personal injury.

▲WARNING: Make sure the hose is free of obstructions or snags. Entangled or snarled hoses can cause loss of balance or footing and may become damaged.

▲WARNING: Use the tool only for its intended use. Do not discharge fasteners into open air. Use the pneumatic tool only for the purpose for which it was designed.

▲WARNING: Use only the fasteners recommended for this tool. Use of the wrong fasteners could result in poor fastener feeding, jammed fasteners, and nails leaving the tool at erratic angles. If fasteners are not feeding smoothly and properly, discontinue their use immediately. Jammed and improperly feeding fasteners could result in serious personal injury.

▲WARNING: Never use this tool in a manner that could cause a fastener to be directed toward anything other than the workpiece. Do not use the tool as a hammer.

▲WARNING: Do not alter or modify this tool from the original design or function without approval from the manufacturer.

▲WARNING: Always be aware that misuse and improper handling of this tool can cause injury to yourself and others. Never leave a tool unattended with the air hose attached.

▲WARNING: Do not operate this tool if it does not contain a legible warning label. Do not continue to use a tool that leaks air or does not function properly.

AIR SUPPLY AND CONNECTION

- ▲WARNING:** Do not use oxygen, combustible gases, or bottled gases as a power source for this tool as tool may explode, possibly causing injury or death.
- ▲WARNING:** Do not use supply sources which can potentially exceed 200 P.S.I.G. as tool may burst, possibly causing injury.
- ▲WARNING:** The connector on the tool must not hold pressure when air supply is disconnected. If a wrong fitting is used, the tool can remain charged with air after disconnecting and thus will be able to drive a fastener even after the air line is disconnected possibly causing injury.
- ▲WARNING:** Do not pull trigger or depress contact arm while connected to the air supply as the tool may cycle, possibly causing injury.
- ▲WARNING:** Always disconnect air supply: 1.) Before making adjustments; 2.) When servicing the tool; 3.) When clearing a jam; 4.) When tool is not in use; 5.) When moving to a different work area, as accidental actuation may occur, possibly causing injury.

LOADING TOOL

- ▲WARNING:** When loading tool: 1.) Never place a hand or any other part of the body in fastener discharge area of tool; 2.) Never point tool at anyone; 3.) Do not pull the trigger or depress the trip as accidental actuation may occur, possibly causing injury.

OPERATION

- ▲WARNING:** Always handle the tool with care: 1.) Never engage in horseplay; 2.) Never pull the trigger unless nose is directed toward the work; 3.) Keep others a safe distance from the tool while tool is in operation as accidental actuation may occur, possibly causing injury.
- ▲WARNING:** The operator must not hold the trigger pulled on contact arm tools except during fastening operation as serious injury could result if the trip accidentally contacted someone or something, causing the tool to cycle.
- ▲WARNING:** Keep hands and body away from the discharge area of the tool. A contact arm tool may bounce from the recoil of driving a fastener and an unwanted second fastener may be driven possibly causing injury.
- ▲WARNING:** Check operation of the contact arm mechanism frequently. Do not use the tool if the arm is not working correctly as accidental driving of a fastener may result. Do not interfere with the proper operation of the contact arm mechanism.
- ▲WARNING:** Do not drive fasteners on top of other fasteners or with the tool at an overly steep angle as this may cause deflection of fasteners which could cause injury.
- ▲WARNING:** Do not drive fasteners close to the edge of the work piece as the wood may split, allowing the fastener to be deflected possibly causing injury.
- ▲WARNING:** Do not point the tool toward yourself or anyone whether it contains fasteners or not.
- ▲WARNING:** Always ensure that the workpiece contact is fully positioned above the workpiece. Positioning the workpiece contact only partially above the workpiece could cause the fastener to miss the workpiece completely and result in serious personal injury.

MAINTAINING THE TOOL

- ▲WARNING:** When working on tools note the warnings in this manual and use extra care when evaluating problem tools.

AIR SUPPLY AND CONNECTIONS

⚠WARNING: Do not use oxygen, combustible gases, or bottled gases as a power source for this tool as tool may explode, possibly causing injury. Keep the tool pointed away from yourself and others when connecting air source.

FITTINGS:

Install a male plug on the tool which is free flowing and which will release air pressure from the tool when disconnected from the supply source.

HOSES:

Air hoses should have a minimum of 150 p.s.i. (10.6 kg/cm²) working pressure rating or 150 percent of the maximum pressure that could be produced in the air system. The supply hose should contain a fitting that will provide "quick disconnecting" from the male plug on the tool.

SUPPLY SOURCE:

Use only clean regulated compressed air as a power source for this tool. NEVER USE OXYGEN, COMBUSTIBLE GASES, OR BOTTLED GASES, AS A POWER SOURCE FOR THIS TOOL AS TOOL MAY EXPLODE.

REGULATOR:

A pressure regulator with an operating pressure of 0 - 125 p.s.i. (0 - 8.79 kg/cm²) is required to control the operating pressure for safe operation of this tool. Do not connect this tool to air pressure which can potentially exceed 200 p.s.i. (14 kg/cm²) as tool may fracture or burst, possibly causing injury.

OPERATING PRESSURE:

Do not exceed recommended maximum operating pressure as tool wear will be greatly increased. The air supply must be capable of maintaining the operating pressure at the tool. Pressure drops in the air supply can reduce the tool's driving power. Refer to "TOOL SPECIFICATIONS" for setting the correct operating pressure for the tool.

FILTER:

Dirt and water in the air supply are major causes of wear in pneumatic tools. A filter will help to get the best performance and minimum wear from the tool. The filter must have adequate flow capacity for the specific installation. The filter has to be kept clean to be effective in providing clean compressed air to the tool. Consult the manufacturer's instructions on proper maintenance of your filter. A dirty and clogged filter will cause a pressure drop which will reduce the tool's performance.

LUBRICATION

Frequent, but not excessive, lubrication is required for best performance. Oil added through the air line connection will lubricate the internal parts. Do not use detergent oil or additives as these lubricants will cause accelerated wear to the seals and bumpers in the tool, resulting in poor tool performance and frequent tool maintenance.

If no airline lubricator is used, add oil during use into the air fitting on the tool once or twice a day. Only a few drops of oil at a time is necessary. Too much oil will only collect inside the tool and will be noticeable in the exhaust cycle.

COLD WEATHER OPERATION:

For cold weather operation, near and below freezing, the moisture in the air line may freeze and prevent tool operation. We recommend the use of permanent antifreeze (ethylene glycol) as a cold weather lubricant.

CAUTION: Do not store tools in a cold weather environment to prevent frost or ice formation on the tools operating valves and mechanisms that could cause tool failure.

NOTE: Some commercial air line drying liquids are harmful to "O"-rings and seals – do not use these low temperature air dryers without checking compatibility.

PRODUCT SPECIFICATIONS

DRIVING POWER	1002 in.lbs
FASTENER TYPE	CLIPPED HEAD NAIL (.113" to .148")
FASTENER RANGE	.2" to 3 1/2"
MAGAZINE CAPACITY	.81 NAILS
WEIGHT	7.7 LBS
OPERATION PRESSURE	70 to 120 PSI
AIR INLET	.1/4" NPT

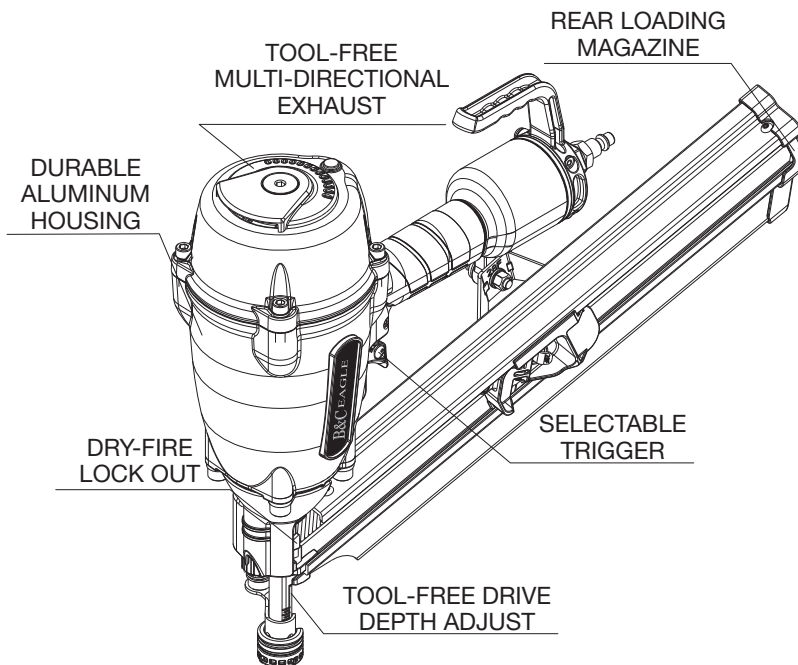

TOOL-FREE MULTI-DIRECTIONAL EXHAUST

The tool-free exhaust can be adjusted to any positions depending on operator preference.

SELECTABLE TRIGGER

The selectable trigger lets the operator choose between from Contact Actuation and Single Sequential Actuation.

TOOL-FREE DRIVE DEPTH ADJUST

The tool-free depth adjust lets the operator select precise driving depth of the fastener.

DRY-FIRE LOCKOUT

The drive-fire lockout extends driver life and prevents missing nails.

REAR-LOADING MAGAZINE

The rear loading magazine offers quick reloading of fasteners.

DEPTH ADJUSTMENT

⚠WARNING: Always disconnect air supply; 1. Before making adjustments; 2. When servicing the tool; 3. When clearing a jam; 4. When tool is not in use; 5. When moving to a different work area, as accidental actuation may occur, possibly causing injury.

The depth adjustment feature provides close control of the fastener drive depth; from flush with the work surface to shallow or deep countersink. First, set the air pressure for consistent drive in the specific work. Then use the depth adjustment to give the desired depth of drive.

TO ADJUST FASTENER CONTROL ADJUSTMENT:

1. Disconnect the tool from the air supply.
2. Turn the depth selector left or right to change the driving depth.
3. Reconnect the tool to the air supply.
4. Drive a test nail after each adjustment until the desired depth is set.

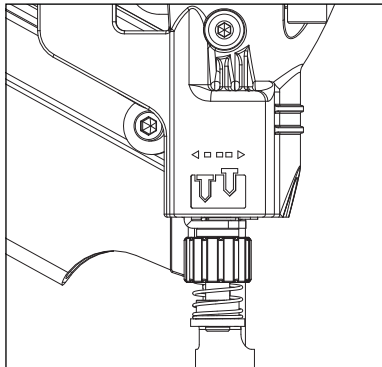

LOADING

TO PREVENT ACCIDENTAL INJURIES:

- ⚠WARNING:**
- Never place a hand or any other part of the body in nail discharge area of tool while the air supply is connected.
 - Never point the tool at anyone else.
 - Never engage in horseplay.
 - Never pull the trigger unless nose is directed at the work.
 - Always handle the tool with care.
 - Do not pull the trigger or depress the trip mechanism while loading the tool.

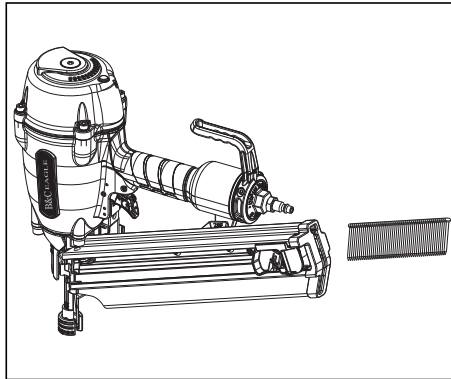

1. Insert nails into track of magazine.

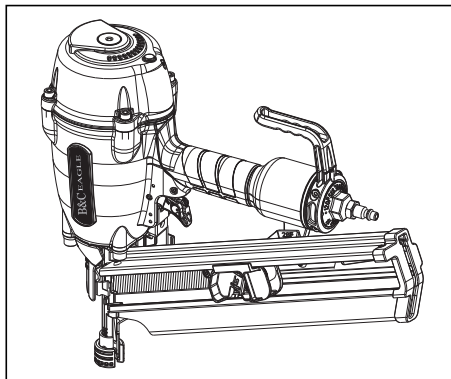

2. Pull pusher all the way back and then allow it to push nails forward to driving position.

TOOL OPERATION

WARNING: **EYE PROTECTION** which conforms to ANSI specifications and provides protection against flying particles both from the **FRONT** and **SIDE** should **ALWAYS** be worn by the operator and others in the work area when connecting to air supply, loading, operating or servicing this tool. Eye protection is required to guard against flying fasteners and debris, which could cause severe eye injury.



The employer and/or user must ensure that proper eye protection is worn. Eye protection equipment must conform to the requirements of the American National Standards Institute, ANSI Z87.1 and provide both frontal and side protection.

NOTE: Non-side shielded spectacles and face shields alone do not provide adequate protection.



CAUTION: Additional Safety Protection will be required in some environments. For example, the working area may include exposure to noise level which can lead to hearing damage. The employer and user must ensure that any necessary hearing protection is provided and used by the operator and others in the work area. Some environments will require the use of head protection equipment. When required, the employer and user must ensure that head protection conforming to ANSI Z89.1 is used.

BEFORE HANDLING OR OPERATING THIS TOOL:

- I. READ AND UNDERSTAND THE WARNINGS CONTAINED IN THIS MANUAL.
- II. REFER TO "TOOL SPECIFICATIONS" IN THIS MANUAL TO IDENTIFY THE OPERATING SYSTEM ON YOUR TOOL.

OPERATION

1. CONTACT TRIP OPERATION:

The CONTACT TRIP is a contact trip that operates in conjunction with the trigger to drive a fastener. There are two methods of operation to drive fasteners with a contact trip tool.

- A. **SINGLE FASTENER PLACEMENT:** To operate the tool in this manner, first position the contact trip on the work surface, **WITHOUT PULLING THE TRIGGER**. Depress the contact trip until the nose touches the work surface and then pull the trigger to drive a fastener. Do not press the tool against the work with extra force. Instead, allow the tool to recoil off the work surface to avoid a second unwanted fastener. Remove your finger from the trigger after each operation.
- B. **RAPID FASTENER OPERATION:** To operate the tool in this manner, hold the tool with the contact trip pointing towards but not touching the work surface. Pull the trigger and then tap the contact trip against the work surface using a bouncing motion. Each depression of the contact trip will cause a fastener to be driven.

WARNING: The operator must not hold the trigger pulled on contact trip tools except during fastening operation, as serious injury could result if the trip accidentally contacted someone or something, causing the tool to cycle.

WARNING: Keep hands and body away from the discharge area of the tool. A contact trip tool may bounce from the recoil of driving a fastener and an unwanted second fastener may be driven, possibly causing injury.

2. SEQUENTIAL TRIP OPERATION:

The SEQUENTIAL TRIP is a contact trip that operates in conjunction with the trigger to drive a fastener. To operate a sequential trip tool, first position the contact trip on the work surface **WITHOUT PULLING THE TRIGGER**. Depress the contact trip and then pull the trigger to drive a fastener. As long as the contact trip is contacting the work and is held depressed, the tool will drive a fastener each time the trigger is depressed. If the contact trip is allowed to leave the work surface, the sequence described above must be repeated to drive another fastener.

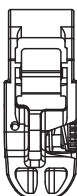

Depress To Allow Selector To Rotate

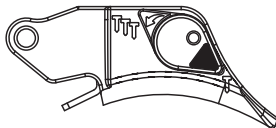

Sequential Trip Operation

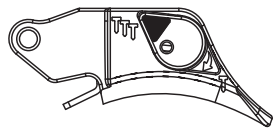

Contact Trip Operation

TOOL OPERATION CHECK

⚠WARNING: Keep the tool away from yourself and others when connecting air source.

CAUTION: Remove all fasteners from tool before performing tool operation check. To reduce the risk of injury to yourself and others, check the tool before beginning work each day or if the tool is dropped, received a sharp blow, been run over, etc. If the tool does not work as it should, contact a B&C Eagle service center immediately.

1. CONTACT TRIP OPERATION:

- A. With finger off the trigger, press the contact trip against the work surface.
THE TOOL MUST NOT CYCLE.
- B. Hold the tool off the work surface, and pull the trigger.
THE TOOL MUST NOT CYCLE.
- C. With the tool off the work surface, pull the trigger. Press the contact trip against the work surface.
THE TOOL MUST CYCLE.
- D. Without touching the trigger, press the contact trip against the work surface, then pull the trigger.
THE TOOL MUST CYCLE.

2. SEQUENTIAL TRIP OPERATION:

- A. Press the contact trip against the work surface, without touching the trigger.
THE TOOL MUST NOT CYCLE.
- B. Hold the tool off the work surface and pull the trigger.
THE TOOL MUST NOT CYCLE.
Release the trigger. The trigger must return to the trigger stop on the frame.
- C. Pull the trigger and press the contact trip against the work surface.
THE TOOL MUST NOT CYCLE.
- D. With finger off the trigger, press the contact trip against the work surface. Pull the trigger.
THE TOOL MUST CYCLE.

IN ADDITION TO THE OTHER WARNINGS CONTAINED IN THIS MANUAL OBSERVE THE FOLLOWING FOR SAFE OPERATION

- Use the B&C Eagle pneumatic tool only for the purpose for which it was designed.
- Never use this tool in a manner that could cause a fastener to be directed toward the user or others in the work area.
- Do not use the tool as a hammer.
- Always carry the tool by the handle. Never carry the tool by the air hose.
- Do not alter or modify this tool from the original design or function without approval from B&C Eagle.
- Always be aware that misuse and improper handling of this tool can cause injury to yourself and others.
- Never clamp or tape the trigger or contact trip in an actuated position.
- Never leave a tool unattended with the air hose attached.
- Do not operate this tool if it does not contain a legible WARNING LABEL.
- Do not continue to use a tool that leaks air or does not function properly. Notify a B&C Eagle service center if your tool continues to experience functional problems.

MAINTAINING THE PNEUMATIC TOOL

⚠WARNING: When working on air tools, note the warnings in this manual and use extra care evaluating problem tools.

CAUTION: Pusher spring (constant force spring). Caution must be used when working with the spring assembly. The spring is wrapped around, but not attached to, a roller. If the spring is extended beyond its length, the end will come off the roller and the spring will roll up with a snap, with a chance of pinching your hand. Also the edges of the spring are very thin and could cut. Care must also be taken to insure no permanent kinks are put in the spring as this will reduce the springs force.

REPLACEMENT PARTS:

B&C Eagle replacement parts are recommended. Do not use modified parts or parts which will not give equivalent performance to the original equipment.

ASSEMBLY PROCEDURE FOR SEALS:

When repairing a tool, make sure the internal parts are clean and lubricated. Use a small amount of oil on all moving surfaces and pivots. After reassembly add a few drops of oil through the air line fitting before testing.

AIR SUPPLY-PRESSURE AND VOLUME:

Air volume is as important as air pressure. The air volume supplied to the tool may be inadequate because of undersized fittings and hoses, or from the effects of dirt and water in the system. Restricted air flow will prevent the tool from receiving an adequate volume of air, even though the pressure reading is high. The results will be slow operation, misfeeds or reduced driving power. Before evaluating tool problems for these symptoms, trace the air supply from the tool to the supply source for restrictive connectors, swivel fittings, low points containing water and anything else that would prevent full volume flow of air to the tool.

CAUTION: If the tool does not work as it should, contact a B&C Eagle service center immediately.

TROUBLE SHOOTING

<u>PROBLEM</u>	<u>CAUSE</u>	<u>CORRECTION</u>	
Frame/nose leaks air	Loose nose screwsTighten and recheck	
	O-ring or Gasket is cut or crackedReplace O-ring or gasket	
	Bumper cracked/wornReplace bumper	
Frame/cap leaks air	Damaged gasket or sealReplace gasket or seal	
	Loose cap screwsTighten and recheck	
Failure to cycle	Air supply restrictionCheck air supply equipment	
	Tool dry, lack of lubricationUse Lubricant	
	Worn head valve O-ringsReplace O-rings	
	Head valve stuck in capDisassemble/Check/Lubricate	
Lack of power; slow to cycle	Tool dry, lacks lubricationUse Lubricant	
	O-rings/seals cut or crackedReplace O-rings/seals	
	Trigger assembly worn/leaksReplace trigger assembly	
	Dirt/tar build up on driverDisassemble nose/driver to clean	
	Cylinder sleeve not seated correctly on bottom bumperDisassemble to correct	
	Head valve dryDisassemble/lubricate	
	Air pressure too lowCheck air supply equipment	
	Skipping fasteners; intermittent feed	Worn bumperReplace bumper
		Tar/dirt in driver channelDisassemble and clean nose and driver
		Air restriction/inadequate air flow through quick disconnect socket and plugReplace quick disconnect fittings
Worn piston O-ringReplace O-ring, check driver	
Tool dry, lacks lubricationUse Lubricant	
Low air pressureCheck air supply system to tool	
Loose magazine nose screwsTighten all screws	
Fasteners too short for toolUse only recommended fasteners	
Bent fastenersDiscontinue using these fasteners	
Wrong size fastenersUse only recommended fasteners	
Leaking head cap gasketTighten screws/replace gasket/ O-ring	
Trigger valve O-ring cut/wornReplace O-ring	
Broken/chipped driverReplace driver (check piston O-ring)	
Fasteners jam in tool	Dry/dirty magazineClean/lubricate use Lubricant	
	Wrong size fastenersUse only recommended fasteners	
	Bent fastenersDiscontinue using these fasteners	
	Loose magazine/nose screwsTighten all screws	
	Broken/chipped driverReplace driver	